

Twinhorn



www.twinhorn.com.tw

T SERIES

CNC LATHE



MODEL:T-6A

SPINDLE SPEED/OUTPUT CHART

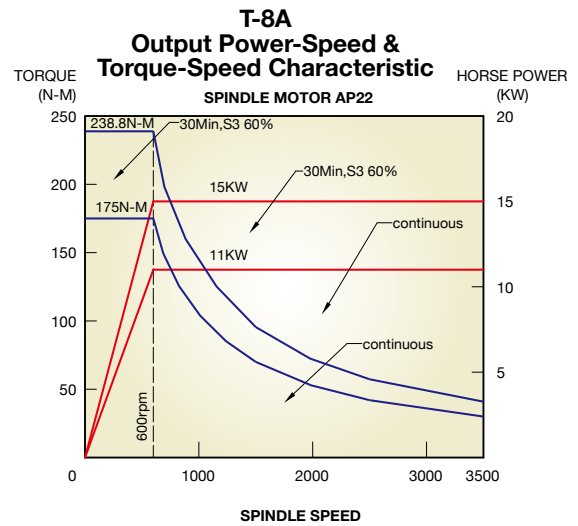
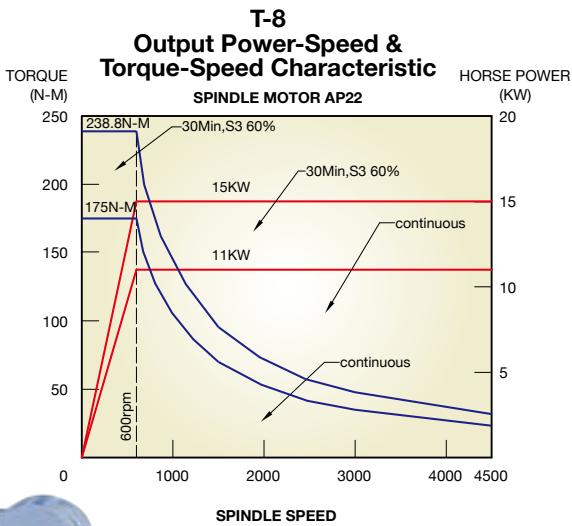
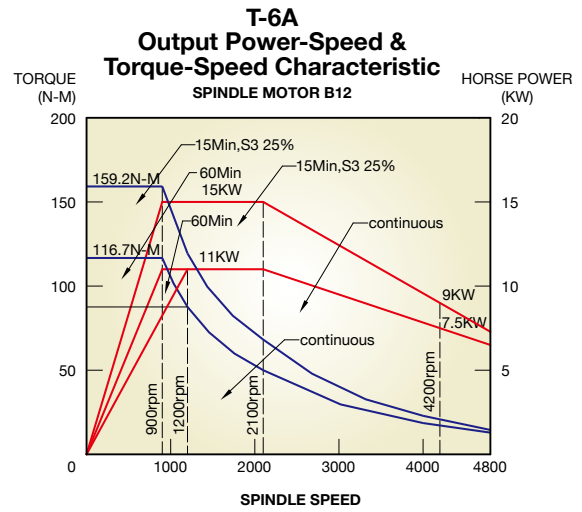
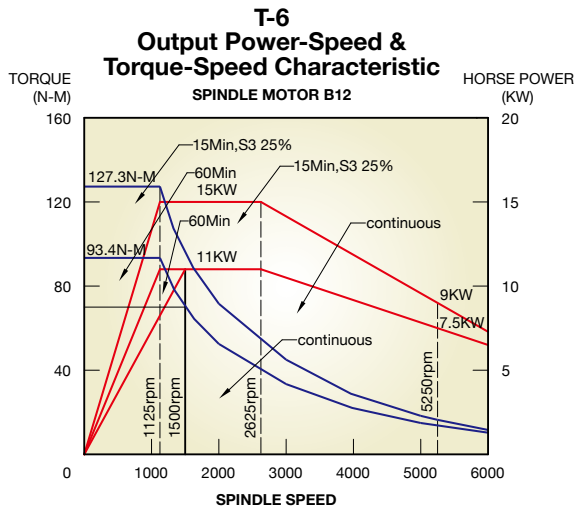

PRECISE, RIGID SPINDLE

- The head stock is manufactured from high tensile Meedhanite cast iron.
- The spindle is precision manufactured from chromolybdenum alloy steel hardness to HRC 54~58.
- The spindle front end employs high precision angular bearings NNK combined with proper spindle support for enhanced accuracy.



T-6/T-6A



T-8/T-8A

T-series CNC LATHE

The new T series CNC lathe from Chi-Fa lets you enjoy all the economy and efficiency of excellent performance.

This new generation of CNC lathe has an exclusive differential bed construction design.

For extraordinary precision, speed and economy, look no further than the new T series from Chi-Fa.

LINEAR GUIDES

- High rigid linear guides provide longer sustained accuracy and greater metal cutting ability.
- Fast rapid traverse increase productivity



T-6/T-6A BED



T-8/T-8A BED

- High hardness high precision of T-8/T-8A steel guides are fitted with chromolybdenum alloy steel.
- The one piece base is manufactured from high tensile meehanite cast iron and has been processed by stress relieved and heat treatment.
- High precision slide-way is manufactured with HRC60 hardness steel. It's also fitted with automatic lubrication system and high precision scraping process to prolong machine life and ensure machine accuracy.



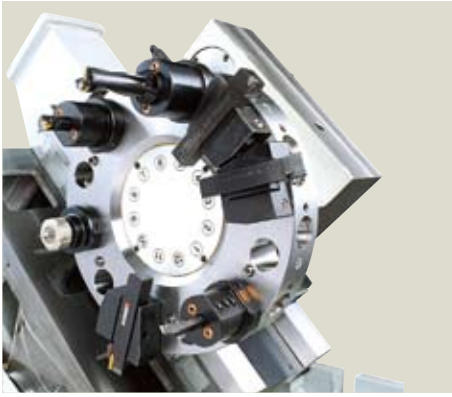

VDI Turret

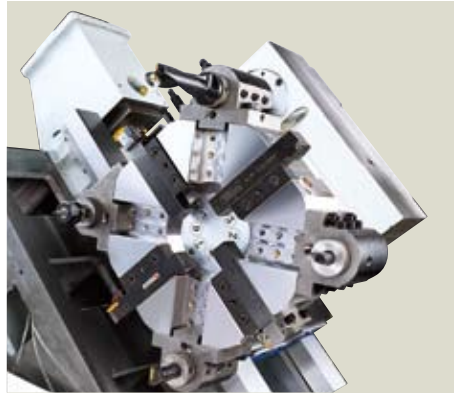

8 Station

SERVO MOTOR DRIVEN TURRET

The VDI & 8 station turret is precisely detected to fully eliminate tool change error.

Tool change is fast accomplished in only 0.8 seconds (adjacent tool for VDI type) Rapid revolution speed 90 rpm 1.2sec/rev.two turret types.

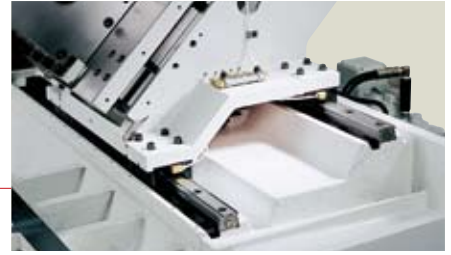

T-6/T-6A

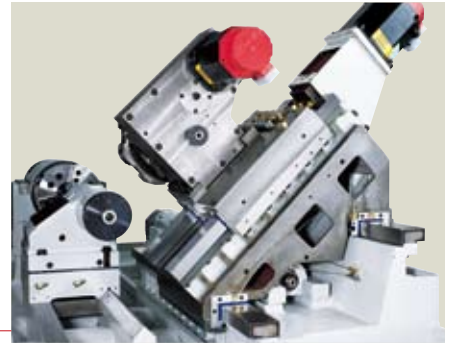

T-8/T-8A

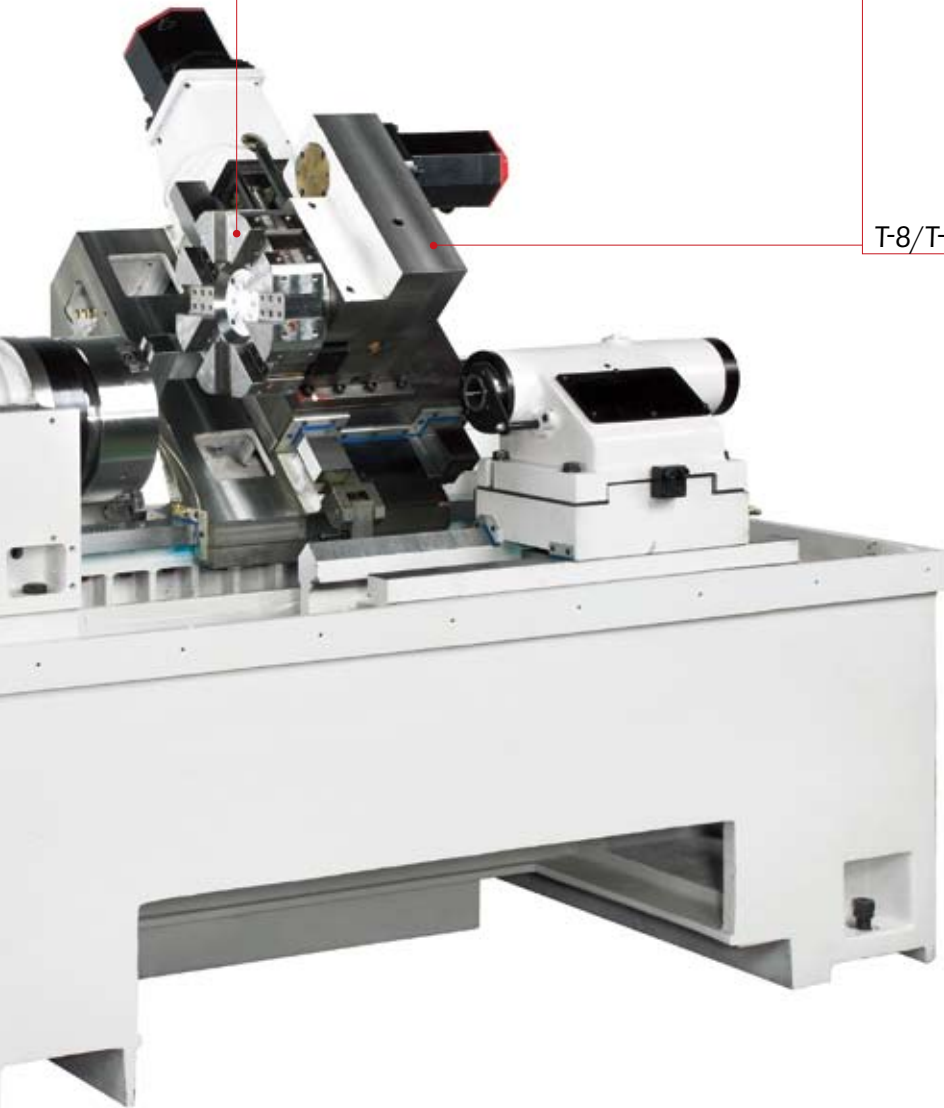

DIFFERENTIAL BED WAYS CONFIGURATION

Designed with advanced Differential Bed Way (ladder structure) configuration, which combines extreme smoothness travel, quick chip removal slant bed, well-distributed working load, and maximum wear resistance in one unit.



HYDRAULIC TAILSTOCK

The whole manually moving tailstock unit is fixed by lock screw and auto tailstock quill is operated by hydraulic power.

VDI Turret TOOL INTERFERENCE DIAGRAM

T-6/T-6A(T-8/T-8A) Dimensions

Unit : mm

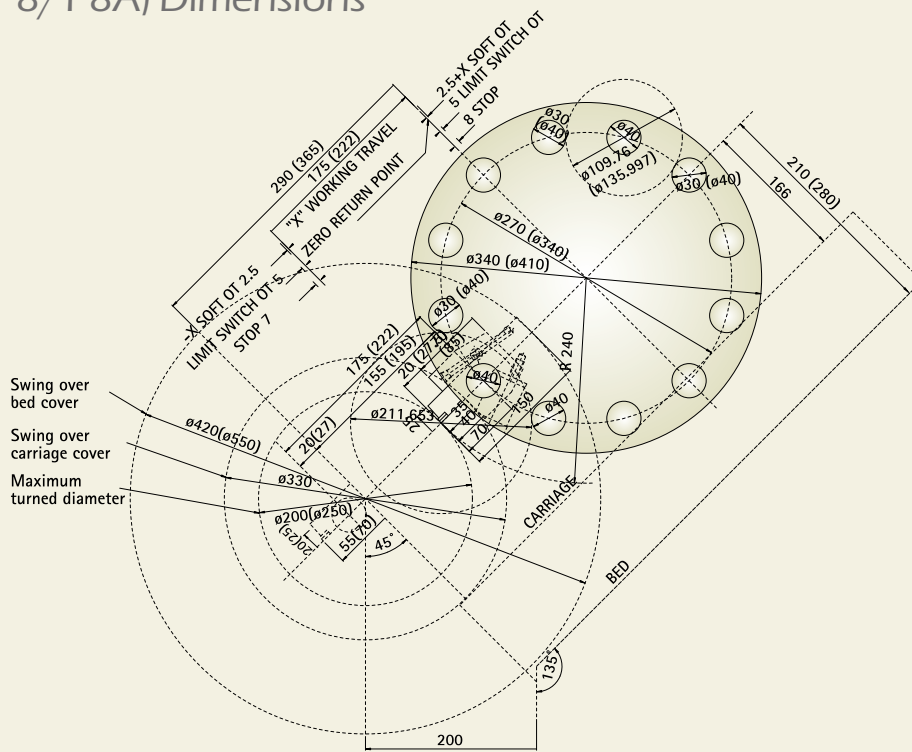

8 Station Turret TOOL INTERFERENCE DIAGRAM

T-6/T-6A(T-8/T-8A) Dimensions

Unit : mm

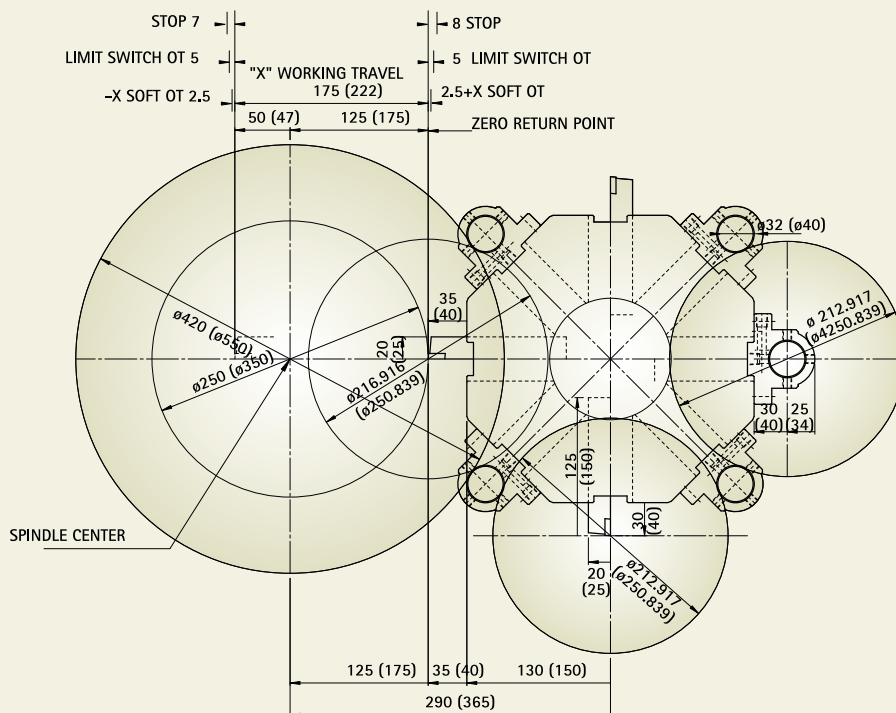

TURRET MOVING RANGE

VDI Turret T-6/T-6A(T-8/T-8A) Dimensions

Unit : mm

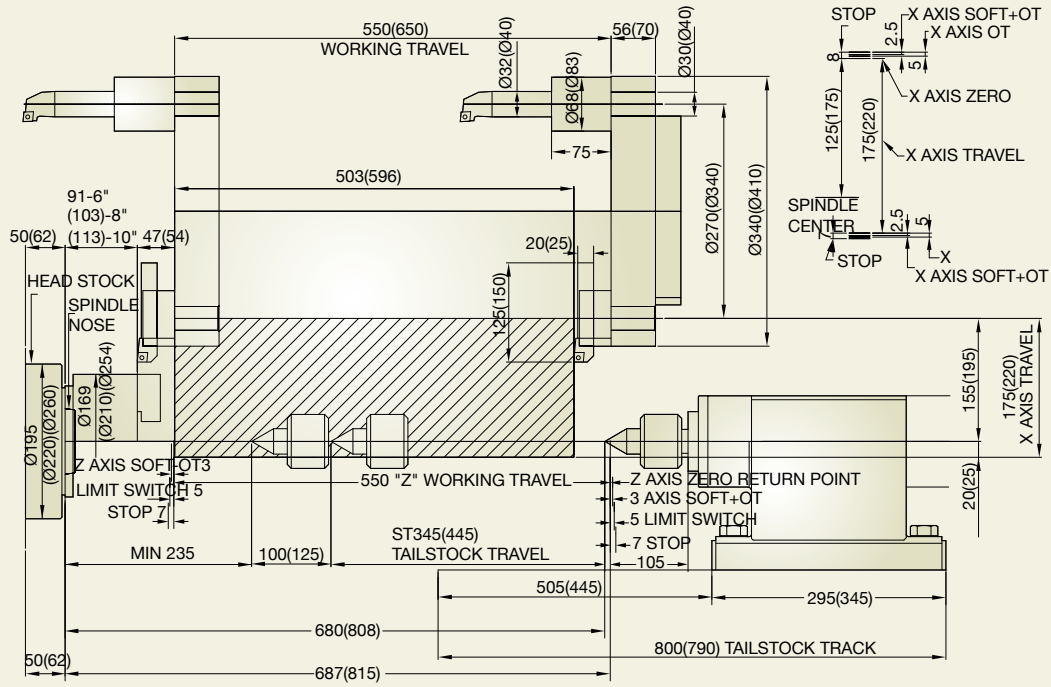

TURRET MOVING RANGE

8 Station Turret T-6/T-6A(T-8/T-8A) Dimensions

Unit : mm

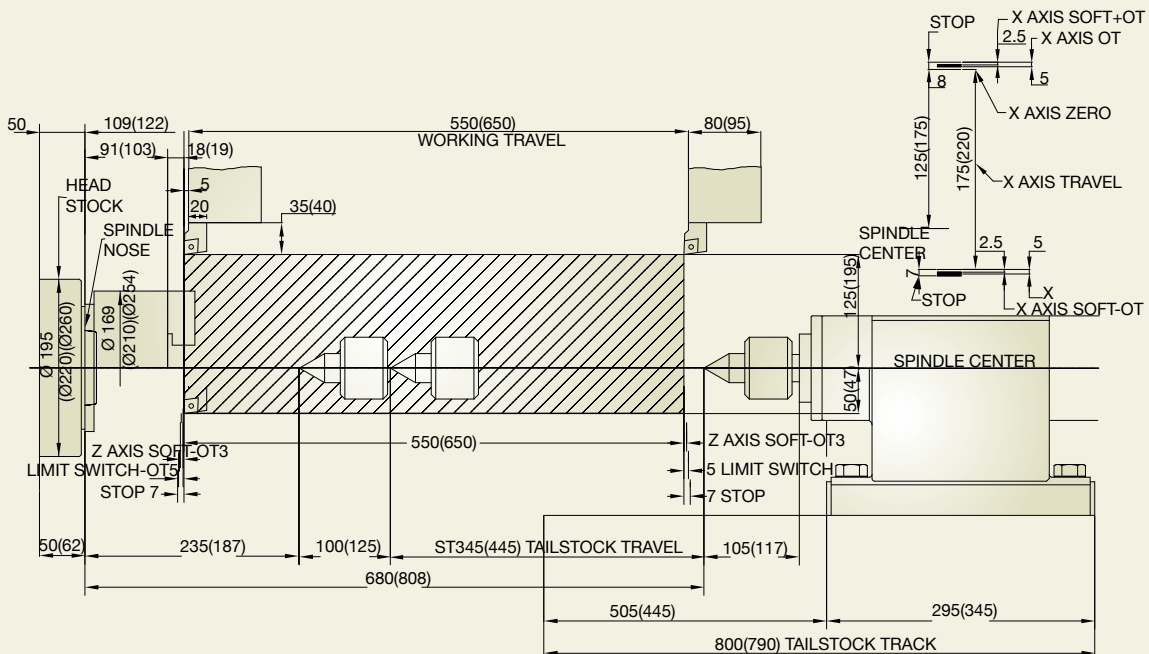

12 STATION VDI TOOLING SYSTEM

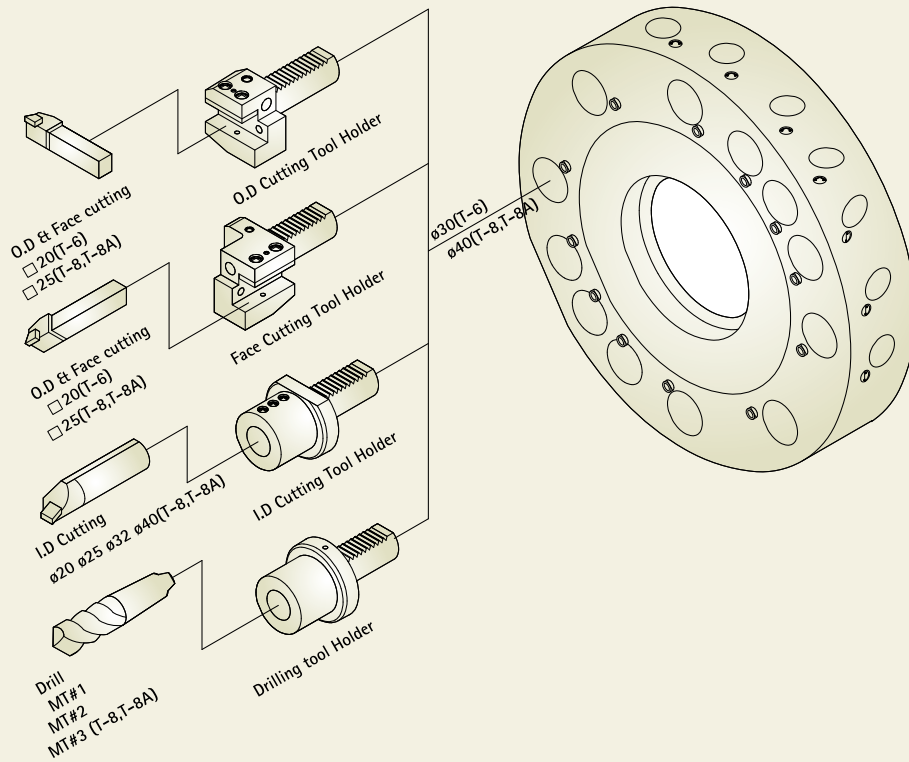

8 STATION TOOLING SYSTEM

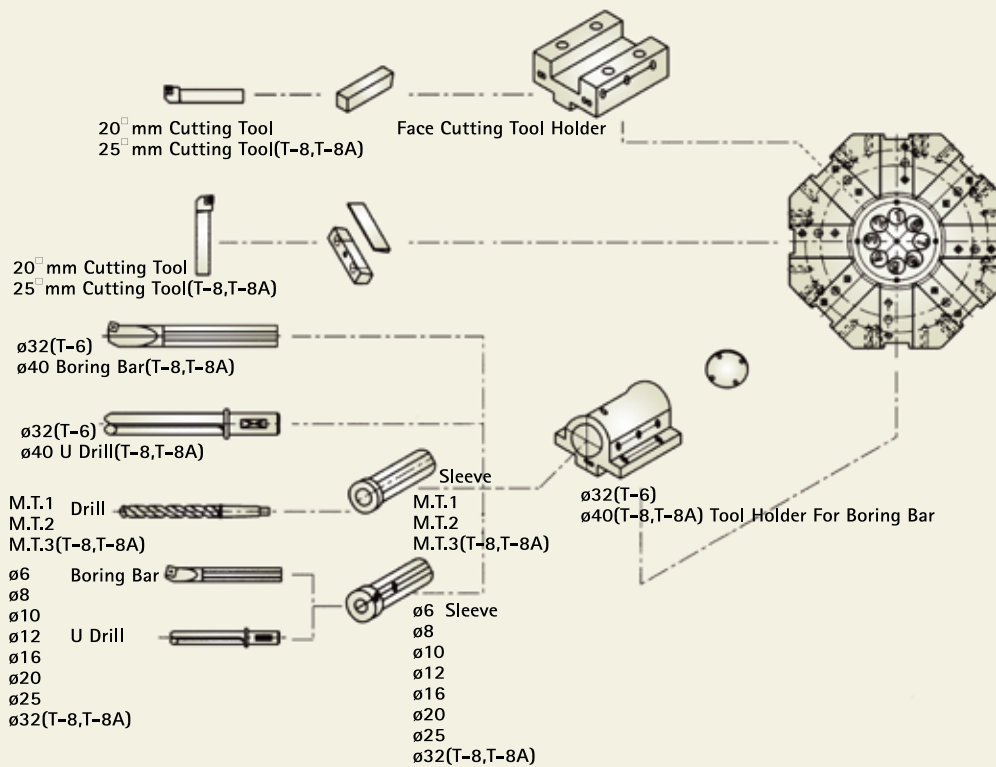

T-6/T-6A(T-8/T-8A)OUTLINE DRAWING

Unit : mm

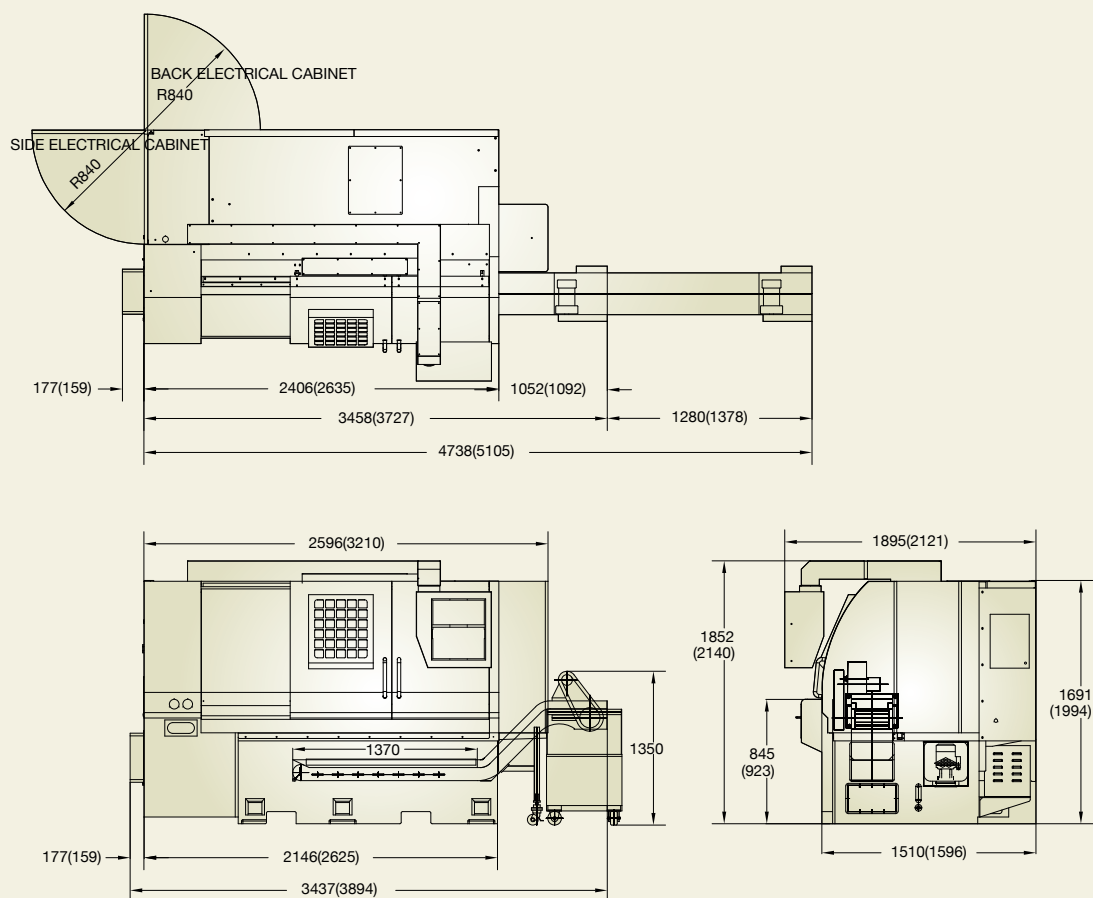

Standard Accessories

- Foot switch for chuck operation
- Tailstock (T-8, T-8A)
- Automatic lubrication system
- Coolant system
- Through hole hydraulic chuck
- Hard jaw 1 set
- Soft jaw 3 set
- Working lamp
- Adjustment tools
- instruction manual
- Heat exchanger
- Chip conveyor and cart
- FANUC Oi controller
- 8 station turret(with accessories)

Optional Accessories

- Automatic power off (M30)
- Tailstock (T-6,T-6A)
- Parts catcher
- Bar feeder
- Transformer for various voltage
- Collet chucks
- Solid power chuck
- CE MARK
- 12 Station VDI tool
- Live tooling
- 10/12 Station turret
- Auto tools preseter
- SIEMENS controller

8 Turret Accessories

- Boring sleeve
ø6,8,10,12,16,20,25,32 1 set
- Drilling sleeve MT3, MT2, MT1 1 set
- F.D cutting holder 1 pcs
- I.D cutting holder 3 pcs
- Deep hole drilling holder 1 pcs

SPECIFICATION

ITEM	T-6/T-6A		T-8 / T-8A	
TRAVEL				
Maximum swing	420mm		550mm	
Swing over carriage cover	330mm		330mm	
Maximum turned diameter	200mm(VDI)/250mm(8 station)		250mm(VDI)/350mm(8 station)	
X axis travel	175mm		220mm	
Z axis travel (maximum turned length)	550mm		650mm(FANUC)	
Carriage inclination	45°		45°	
SPINDLE				
	A2-5	A2-6	A2-6	A2-8
Spindle center height (from floor)	920mm		950mm	
SPINDLE NOSE				
Power chuck diameter	6"(ø169mm)	8"(ø210mm)	8"(ø210mm)	10"(ø254mm)
Power chucking system	Hydraulic		Hydraulic	
Spindle bore	ø56mm	ø62mm	ø62mm	ø87mm
Hole through draw bar	ø45mm	ø52mm	ø52mm	ø75mm
Spindle front bearing (internal diameter)	ø90mm	ø100mm	ø100mm	ø130mm
Max. spindle speed (as standard/optional)	6000R.P.M.	4800R.P.M.	4500R.P.M.	3500R.P.M.
Spindle motor	11kw/15kw(FANUC)		11kw/15kw(FANUC)	
Min. spindle speed for full motor power	1125R.P.M.	900R.P.M.	600R.P.M.	600R.P.M.
AXIS				
X and Z axis rapid traverse rate	12 and 20m/min		12 and 20m/min	
X axis slide way configuration	Double Linear Way		steel way	
Z axis slide way configuration	Double Linear Way		steel way	
TURRET SYSTEM				
Tool change type	servo motor drive		servo motor drive	
Turret disc diameter	ø340mm(VDI)/ø260mm(8 Station)/ ø280mm(10 Station)		ø410mm(VDI)/ø300mm(8 Station)/ ø350mm(10 Station)	
Type	VDI(30)/8 station/10 station		VDI(40)/8 station/10 station	
Number of tool stations	VDI(12)/8 station(8)/10 station(10)		VDI(12)/8 station(8)/10 station(10)	
Turning tool shank dimensions	20x20mm		25x25mm	
Max. boring bar diameter	ø32mm		ø40mm	
Tool travel below center line	20mm		27mm	
TAILSTOCK				
Tail stock quill taper	No.4 MT		No.5 MT	
Quill diameter and travel	ø75x100mm		ø95x125mm	
Max. quill thrust	550kgf(18kgs/cm ²)		960kgf(18kgs/cm ²)	
GENERAL INFORMATION				
Slide way lubrication system	Auto		Auto	
Approximate machine footprint	1750x3010x1850/1750x3570x1900		2000x3550x1960	
Approximate machine weight	3800kgs		4700kgs	
Coolant tank capacity	115Liter		165 Liter	

Product specifications, accessories, and machine appearance are subject to change without prior notice



CHI-FA MACHINERY MANUFACTURER CO., LTD.

NO.44 MING-CHUAN RD., SHENG KANG HSIANG,
TAICHUNG HSIEN, TAIWAN
TEL:+886-4-25628747
FAX:+886-4-25614199
<http://www.twinhorn.com.tw>
E-mail:chifaltd@ms36.hinet.net / info@twinhorn.com.tw

TWINHORN MACHINERY CO., LTD.

NO.735 LIU-DUN VILLAGE, NAN-QIAO TOWN,
FENG-XIAN DISTRICT, SHANGHAI
TEL: +86-21-3752 3721
FAX:+86-21-3752 3722

HEBEI ZHAOFA MECHANTRONIC CO., LTD.

HEBEI CANGZHOU BOTOU INDUSTRIAL PARK

TWINHORN USA LLC

2839 Durban Road Sandy, UT 84093
TEL:+1-801-897-0788
FAX:+1-801-733-4853
<http://www.twinhornusa.com>
E-mail:charles_lee@twinhornusa.com